

# Dehumidifier WDH-416S

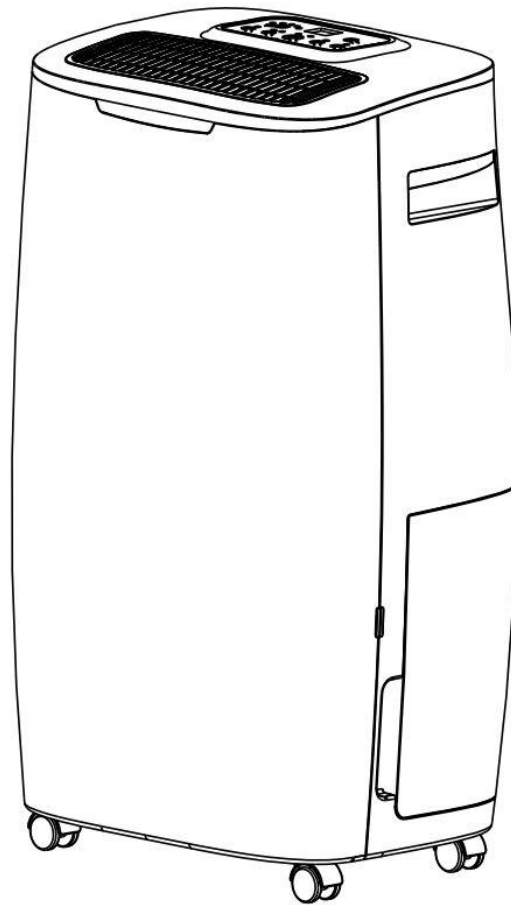

Dear Customer,

You have chosen a high quality product. To ensure that you get a lot of enjoyment from this product, here are a few more tips:

### **After transport:**

Since the unit uses refrigerant, improper transport can sometimes occur despite careful instructions on the carton. For this reason, we ask you to leave it standing upright for at least 4 hours before using the unit for the first time, so that the refrigerant can settle properly in the unit.

### **In case of any problems:**

We hope the device meets your expectations! If, despite the greatest possible care, there should ever be cause for complaint, we ask you to contact us briefly, as we are very concerned about your satisfaction and would like to clear up any misunderstanding.

### **On first operation:**

As the internal piping comes into contact with moisture for the first time, it can take up to approx. 3 hours for the first liquid to accumulate in the collection container, depending on the humidity.

### **Start-up time / delay:**

To protect the compressor, the unit does not switch it on again immediately after it has stopped operating or there has been an interruption in operation (e.g. emptying the condensation tank). The unit is initially in a so-called "protection mode" for about 3 minutes, in which only the fan runs and the compressor does not switch on. The green operating light also only switches on again after the protection/waiting time has elapsed.

## **Room humidity and dehumidification performance:**

If you wish to check the room humidity and the associated dehumidification performance with your own humidity meter (hygrometer), please avoid mounting this humidity meter on a wall, as this will falsify the true humidity content of the room air. See also the explanations under Troubleshooting !!!

## **Important safety instructions:**

- When setting up, using and cleaning the unit, follow the operating instructions strictly and read them very carefully!
- Supervise the dehumidifier when children are near the unit !
- Watch out for electricity, never walk into or insert objects into the unit !
- Do not place any objects on the dehumidifier !
- Do not block the exhaust air fins of the unit and please ensure sufficient space/clearance at and around the fan !
- Make sure that there is sufficient air supply to the device, otherwise it can lead to a reduction in performance and, in the worst case, to overheating and/or fire !
- Make sure that no moisture gets to the electrical system of the device !
- Use only the recommended voltage for the operation of the device !
- Make sure that the power cable is unfolded (untied) before connecting it to the power outlet !
- Make sure that the plug is cleanly and properly connected to the socket before operating the device !
- In case of problems or damage always contact the manufacturer immediately and never repair it yourself !
- Never reach near the plug or socket with wet hands !
- Please do not use multiple sockets for operating the dehumidifier !
- Do not repair defective or damaged cables on the device yourself, you could get a severe electric shock !
- Make sure that highly flammable substances (e.g. gases/oils etc.) are never in the vicinity of the device !
- If you do not use the device for a longer period of time, switch it off and disconnect the mains plug !
- This appliance is not intended for use by persons (including children) with reduced physical, sensory or mental capabilities, or lack of experience and/or knowledge, unless they have been given supervision or instruction concerning use of the appliance by a person responsible for their safety.
- Do not make any changes to the device !
- The dehumidifier should not be operated or stored in a room with other burning/heating appliances !

Please switch off the device immediately and remove it from the power/mains if something seems to be wrong !!! In this case, please contact a specialist and do not attempt to repair the device yourself !!!

**Examples:** Fan does not run during operation, fuse has blown, or compressor rattles loudly.

## **Important operating and safety information regarding the R290 refrigerant in this unit:**

- Read these instructions carefully and follow them strictly !
- The unit operates with the refrigerant R290. This refrigerant is highly flammable and explosive if the safety instructions are not observed!
- The device should not be stored or operated in a room with burning/heating appliances or open fire !
- Please note that the refrigerant is odourless and a leak cannot be detected immediately by an odour!
- Make sure that the outlet of the exhaust air is always ensured and is not obstructed by other objects !
- Ensure a minimum distance of at least 50 cm from open flames and heating elements !
- Assembly, operation as well as storage of the device should take place in a room with a minimum size of 4 m<sup>2</sup> !
- When cleaning, proceed strictly according to the manufacturer's instructions and do not use any additional heat sources to possibly accelerate the defrosting process of the appliance !

**This device has parts that must not be replaced or repaired !**

**The refrigerant cannot be renewed or replaced !**

**Do not carry out any independent repairs or modifications to your device !**

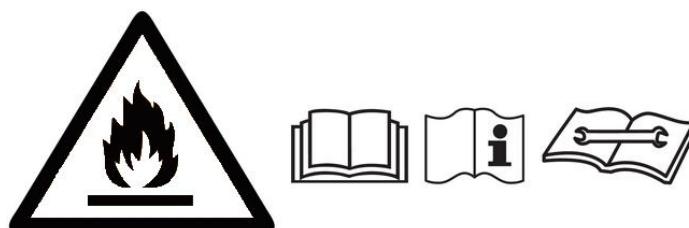

## Description of the device parts:

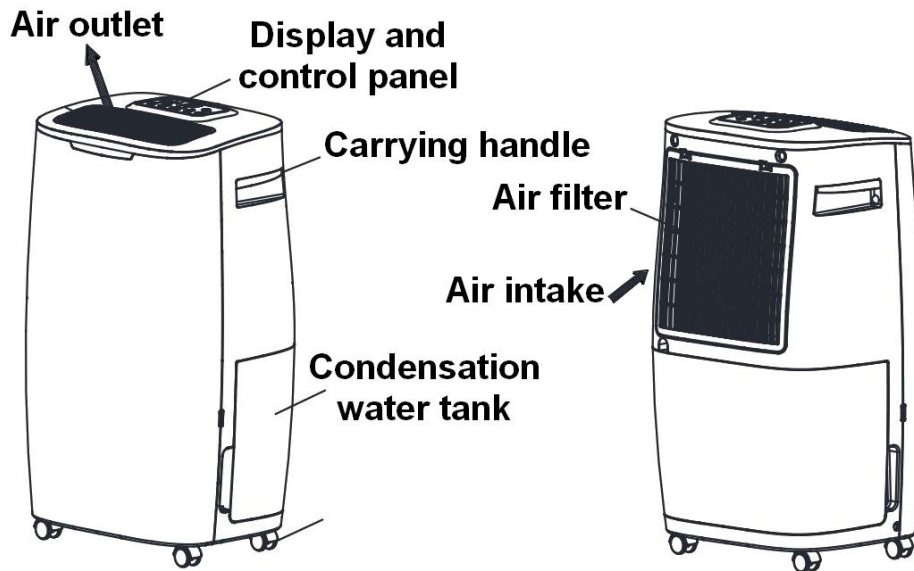

## Functional Description:

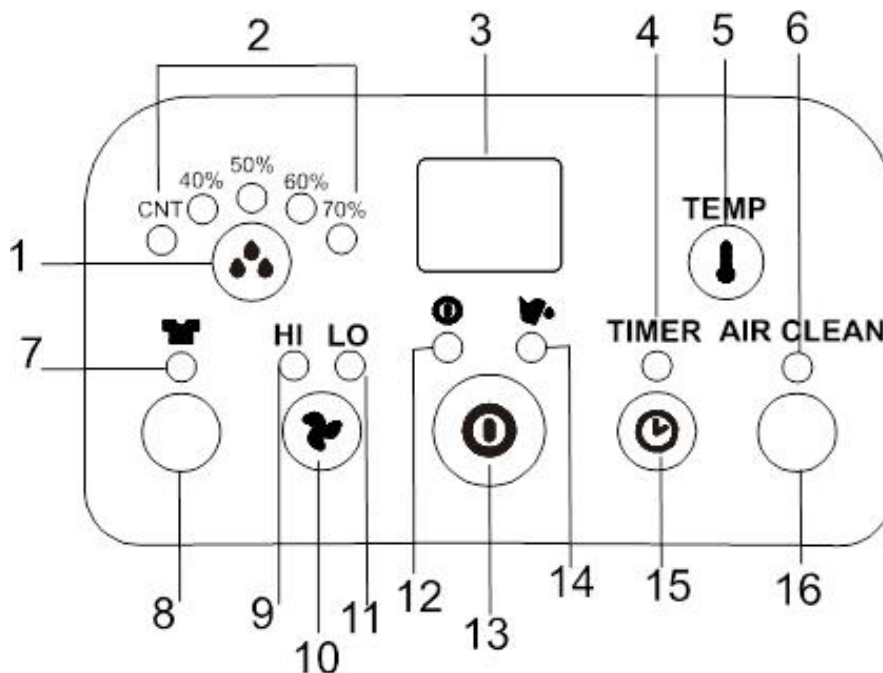

- |  |  |
|--|--|
| <ul style="list-style-type: none"> <li>1.) Button for setting the desired humidity</li> <li>2.) Signal lights of the set humidity</li> <li>3.) Display panel for humidity and timer</li> <li>4.) Signal light of the active timer function</li> <li>5.) Button for displaying the current temperature</li> <li>6.) Signal light "Air circulation mode active" (air cleaning)</li> <li>7.) Laundry drying mode activated signal light</li> <li>8.) Button for activating the laundry drying mode</li> </ul> | <ul style="list-style-type: none"> <li>9.) High air circulation active" signal light</li> <li>10.) Button for setting the air circulation</li> <li>11.) Low air circulation active" signal light</li> <li>12.) Operating people</li> <li>13.) On/Off button</li> <li>14.) "Tank full" signal light</li> <li>15.) Button for activating the timer function</li> <li>16.) Button for activating the air circulation mode (air purification)</li> </ul> |
|--|--|

## Directions for use:

### 1. Commissioning

- 1.1 Insert the power plug properly into the power outlet.
- 1.2. Check that the condensation tank is properly seated in the dehumidifier. (When using the dehumidifier for the first time, it is possible that the "condensation tank full" light is illuminated. Simply pull the condensation tank out briefly and then push it right back in again and you are ready to go! )
- 1.3 Switch on the device with the operating switch (on/off button). Now press the humidity setting button and set your target humidity as desired. The target value "CNT" corresponds to continuous operation ! The value you set must be below the current room humidity for the unit to dehumidify. If your value is above the current room humidity, the fan runs for 3 minutes and the unit then switches off. If the room humidity rises above the set value, the device automatically starts dehumidification operation again.
- 1.4 Use the air circulation adjustment button to select between low and high fan speed / air circulation.
- 1.5. If you want to activate/use the timer function (function for determining the remaining time or function for specifying a start time), press the TIMER button.

Determining the remaining run time: Press the TIMER button during operation to select the desired remaining run time of the dehumidifier. (A value between 1 - 24 hours can be selected). After this selected operating time has elapsed, the device switches off automatically.

Determining a start time: When the dehumidifier is switched off, press the TIMER button to select the desired start time. (A value between 1 - 24 hours can be selected). After this selected time has elapsed, the appliance switches on automatically (with the last settings used, provided the mains plug has not been disconnected in the meantime).

- 1.6. If you want to use the laundry drying mode, press the button to activate the laundry drying mode. In the laundry drying mode, the air circulation is continuously set to high.dehumidified. The appliance operates in continuous mode here. Exit the laundry drying mode by pressing pressing the button again to activate the laundry drying mode.
- 1.7. In the air circulation mode ( air purification ) only the fan operates and no dehumidification takes place. Start and stop this setting, by pressing the button to activate the Air circulation mode (air purification).

### 2. Emptying the collection tank / When the "Condensation tank full" light is on

When the condensation tank is full, the signal light comes on and the dehumidifier then automatically stops its dehumidification operation. Remove the condensation tank and empty it. After you have pushed the condensation tank neatly back into the device, the dehumidification operation starts again automatically.



### 3. Connecting a hose

- 3.1. You will need a ½ inch plastic hose.
- 3.2. Remove the condensation tank for a short time.
- 3.3. Pass the plastic hose through the opening above the condensation tank and then connect it to the drip tap (see diagrams below). Then push the condensation tank neatly back into the appliance
- 3.4. Proper drainage of the condensation water with hose connection ! Make sure that the hose always has a slight downward slope (see following diagrams).



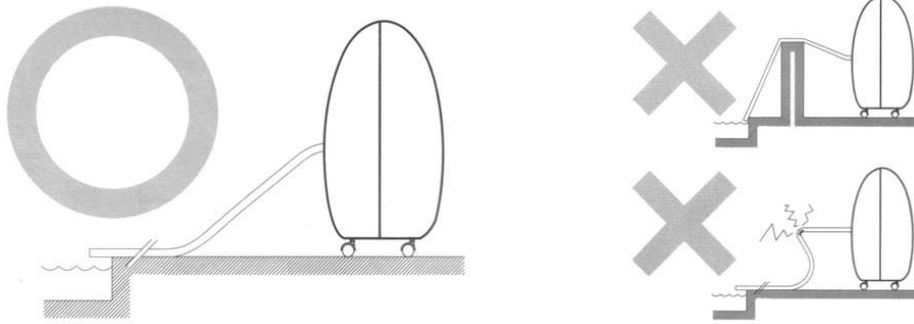

## 4. Other operating instructions

- 4.1. Do not disconnect the mains plug by pulling on the power cable !
- 4.2. Do not use insect spray, oil spray, paint spray, etc. near the dehumidifier. This may cause damage to the unit or even fire !
- 4.3. Do not place the device on sloping or uneven surfaces !
- 4.4. Please always keep a distance of approx. 20 cm to the wall to avoid possible overheating of the appliance. Furthermore, please also ensure a distance of approx. 50 cm upwards when drying laundry !
- 4.5. For effective and economical dehumidification operation, please close all doors and windows in the dehumidifier room !
- 4.6. Please keep the device away from heat sources !
- 4.7. Always hold the device in its proper and upright position and transport !

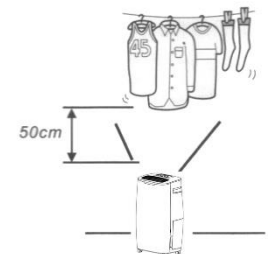
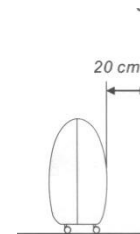
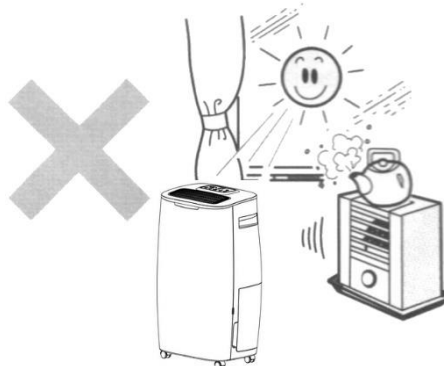
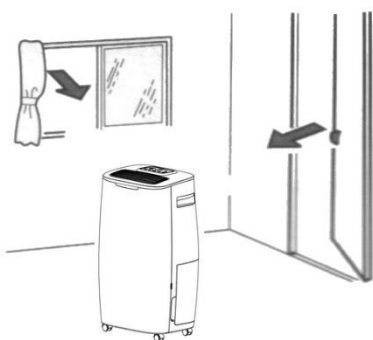
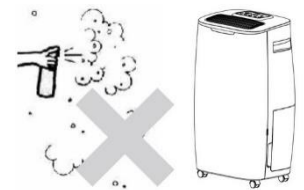
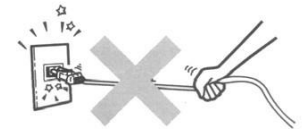

## 5. Cleaning

### 5.1. Cleaning the housing

- Please unplug the dehumidifier from the mains before cleaning.
- Use only mild detergents to clean your dehumidifier.
- NEVER spray your dehumidifier (e.g. with water or similar).

### 5.2. Cleaning the air filter

The air filter filters lint, hair and coarse dust. The air filter is coated with an antibacterial glaze to inhibit the proliferation of bacteria. Furthermore, the air filter ensures that less dust is deposited on the cooling fins and thus ensures higher efficiency.

- Always clean the filter when it can be assumed that the air intake is reduced by the dirty air filter !
- Then remove the air filter from its holder (the filter grid).
- It is best to clean the air filter carefully under lukewarm water or with a weakly adjusted (suction power) vacuum cleaner.
- Reattach the air filter/strainer to the filter grille and reattach to the back of the unit - DONE.

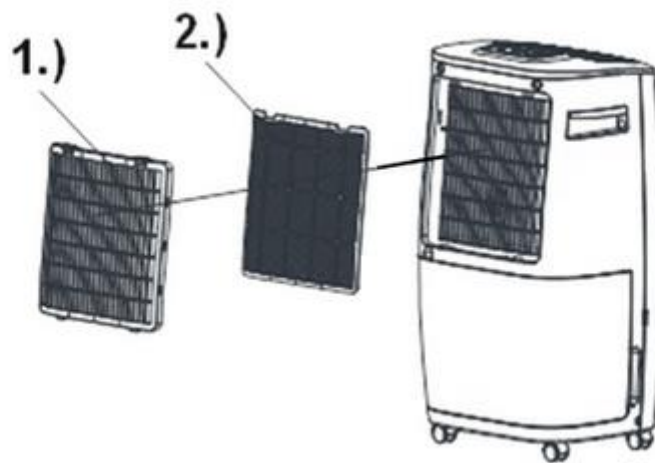

1.) Filter grid

2.) Washable filter screen

## Technical data:

<b>Model Name:</b>	WDH-416S
<b>Voltage:</b>	220 ~ 240V / 50Hz
<b>Max. Power consumption:</b>	415 W
<b>Compressor:</b>	Rotary compressor
<b>Dehumidification capacity (optimal):</b>	20 lfr./day (35°C / 90% r.h.)
<b>Dehumidification capacity (standard):</b>	16 lfr./day (30°C / 80% r.h.)
<b>Condensation tank:</b>	Approx. 3,5 litres
<b>Refrigerant:</b>	R290 (60 g)
<b>Protection class:</b>	IPX0
<b>Dimension (H/W/D):</b>	553 x 310 x 236 mm
<b>Weight:</b>	14 kg
<b>Range of use:</b>	5°C ~ 32°C

## Troubleshooting:

### The unit does not dehumidify enough / Too little water accumulates in the condensation tank

Please remember that the primary objective is not to gain as much condensation water as possible, but to dry and/or keep the room air or ceilings, walls and inventory dry !

Furthermore, remember that the dehumidifier can only remove moisture from the air and only indirectly from materials.

Depending on the condition of the ceilings, walls and fixtures, it can take several weeks until they have released the stored moisture back into the air! For this reason, we also recommend that if you use your own humidity meter (hygrometer), to place it as freely as possible and somewhat away from walls and ceilings, because otherwise the determined humidity value of the room air is falsified!

As with all dehumidifiers, the dehumidification performance is decisively influenced by the following factors:

A) humidity content of the room air and B) heat/temperature in the room.

Therefore, for safety's sake, here is an excerpt from the dehumidification table at DAUERBETRIEB:

<b>35 degrees</b> and <u>80% r.h.</u> = approx. 18 litres	and at <u>90% r.H.</u> = approx. 20 litres	and at <u>60% r.H.</u> = approx. 10 litres
<b>30 degrees</b> and <u>80% r.h.</u> = approx. 16 litres	and at <u>90% r.H.</u> = approx. 18 litres	and at <u>60% r.H.</u> = approx. 8 litres
<b>20 degrees</b> and <u>80% r.H.</u> = approx. 9 litres	and at <u>90% r.H.</u> = approx. 11 litres	and at <u>60% r.H.</u> = approx. 5 litres
<b>15 degrees</b> and <u>80% r.H.</u> = approx. 7 litres	and at <u>90% r.H.</u> = approx. 8 litres	and at <u>60% r.H.</u> = approx. 3 litres
<b>10 degrees</b> and <u>80% r.h.</u> = approx. 4 litres	and at <u>90% r.H.</u> = approx. 5 litres	and at <u>60% r.H.</u> = approx. 2 litres
<b>5 degrees</b> and <u>80% r.h.</u> = approx. 3 litres	and at <u>90% r.H.</u> = approx. 4 litres	and at <u>60% r.H.</u> = approx. 1 litre

All data are approximate per day (fluctuation tolerance) with a measurement directly at the device input and of course these values are only valid with constant temperature and moisture content!

### The device rattles or makes running noises

Running noises are mostly caused by the air filter unit. We kindly ask you to remove the air filter once and check whether the running noises are still present to the same extent ?

An unfavourable position of the dehumidifier is often the reason for higher running noises. Try changing the position a little, as the running noises will then mostly disappear. Optimum and particularly quiet operation can be achieved if the dehumidifier is placed on a piece of carpet, doormat or similar during operation! (Stone floors, tiles, laminate or parquet, on the other hand, increase the operating noise of the dehumidifier! )

### The device is leaking or water is leaking out

In this context, we would like to provide you with the following information:

A "leak" on your dehumidifier is actually impossible, unless the main frame is broken and of course something like that can be ruled out without force.

If the water still leaks out, then the condensate probably comes from the "emergency drain", which is located behind the collection tank at the very top right in a small triangular recess. The reason for this is that the normal drain is prevented. This can have the following causes:

1. The most common cause is a slight soiling in the drip tray or the left drain (e.g. due to dead insects, dirt or similar) and therefore the condensate cannot drain off normally. In this connection, please check the left drain once or shake the unit once briefly in the upside-down position. Make sure that you then wait at least 4 hours before switching the unit on again!
2. The device does not have a straight stand.
3. It may be that only a large piece of ice has detached from the cooling fins of your dehumidifier and this leads to a short-term blockage. We therefore recommend that you disconnect the unit completely from the power supply for a day and then the unit should no longer "leak".

## Other:

### **Warranty Statement:**

Notwithstanding the statutory warranty claims, the manufacturer grants a warranty in accordance with the laws of your country, but at least 1 year (in Germany 2 years for private individuals). The start of the warranty is the date of sale of the device to the end user.

The warranty only covers defects that are due to material or manufacturing faults.  
are.

Warranty repairs may only be carried out by an authorised service centre. To  
To make your warranty claim, please enclose the original sales receipt (with date of sale).

Excluded from the warranty are:

- Normal wear and tear
- Improper use, such as overloading the device or unapproved accessories.
- Damage due to external influences, use of force or foreign bodies
- Damage caused by non-observance of the operating instructions, e.g. connection to the wrong mains voltage or non-observance of the assembly instructions.
- Completely or partially dismantled equipment

### **Conformity:**

The dehumidifier has been tested and itself and/or parts thereof have been manufactured under the following (safety) standards:

**"GS" tested by Intertek, and of course with CE conformity and EMC conformity.**

Tested safety according to: EN 60335-2-40:2003+A11:2004+A12:2005+A1:2006+A2:2009+A13:2012  
EN 60335-1:2012+A11:2014+A13:2017+A1:2019+A2:2019+A14:2019  
EN 62233:2008  
AfPS GS 2019:01 PAK

CE (LVD) Conformity tested according to: EN 60335-2-40:2003+A11:2004+A12:2005+A1:2006+A2:2009+A13:2012  
EN 60335-1:2012+A11:2014+A13:2017  
EN 62233:2008

EMC conformity tested according to: EN 55014-1:2017  
EN 55014-2:2015  
EN 61000-3-2:2014  
EN 61000-3-3:2013

### **Correct disposal of this product:**



Within the EU, this symbol indicates that this product should not be disposed of with other household waste. Waste equipment contains valuable recyclable materials that should be recycled. In addition, the environment or human health should not be harmed by uncontrolled waste disposal. Therefore, please dispose of old devices via suitable collection systems or send the device for disposal to the place where you purchased it. They will then recycle the device.

■  
We wish you much pleasure with this device

*Your Aktobis AG*

***Keep these instructions for use in a safe place !***